



CITY OF DE PERE

Engineering Division

925 S. Sixth Street, De Pere, WI | 920-339-4061 | www.deperewi.gov/engineering

PERMIT # _____

PERMIT APPLICATION
Construct/Operate/Maintain Utilities within Municipal Right-of-Way

Applicant/Company Information

Owner Name: _____	Contact Person: _____
Current Address: _____	Emergency Phone: _____
City, State, ZIP : _____	Phone: _____
Email: _____	Fax: _____
Plans prepared by: _____	Phone: _____

CONTRACTOR INFORMATION

Contractor Name: _____	Contact Person: _____
Current Address: _____	Emergency Phone: _____
City, State, ZIP : _____	Phone: _____
Email: _____	Fax: _____

LOCATION INFORMATION

Street Address/Location Description: _____

PERMIT APPLICATION FEE PART (I)	√	WORK TO BE PERFORMED FEE PART (II)	√
Open Cut Excavation Fee waived if need For open-cut caused by Public Health, Safety or Welfare Emergency	No Fee	**All fees waived for Emergency Excavations	
Small Utility project permit (less than 1000' of roadway)	\$82.50	Excavation in Right of Way outside of Street area	\$82.50
Medium Utility project permit (1000' to 3000' of roadway)	\$154.50	Boring within Street Right of Way - servicing one property and sewer is located behind curb	\$82.50
Large Utility project permit (3000' to 5000' of roadway)	\$227.00	Boring within Street Right of Way	\$556.50
Very Large Utility project Permit (5000' of roadway)	Actual Cost	Road/Street open-cut Excavation within Street Pavement Area	\$1,123.00

(I) Permit Application Fee	\$ _____	
(II) Work to Be Performed	\$ _____	*Utility Permit Fee waived if utility project is done in conjunction with street construction project as long as utilities are constructed prior to curb and gutter and final paving.
TOTAL UTILITY PROJECT PERMIT FEE*	\$ _____	*

DESCRIPTION OF PROPOSED WORK

Utility Type:	<input type="checkbox"/> Gas/Petroleum	<input type="checkbox"/> Electric	<input type="checkbox"/> Communications	<input type="checkbox"/> Sanitary Sewer	<input type="checkbox"/> Water
<input type="checkbox"/> Private Line	<input type="checkbox"/> Transmission	<input type="checkbox"/> Distribution	<input type="checkbox"/> Service	<input type="checkbox"/> Facility Size/Capacity: _____	
Orientation:	<input type="checkbox"/> Overhead	<input type="checkbox"/> Underground	<input type="checkbox"/> Parallel to Road Centerline	<input type="checkbox"/> Municipal Road	
<input type="checkbox"/> Tunnel	<input type="checkbox"/> Other: _____				
Work Type:	<input type="checkbox"/> New Construction	<input type="checkbox"/> Improve/Repair Existing	<input type="checkbox"/> Maintenance	<input type="checkbox"/> Removal	
<input type="checkbox"/> Abandon in Place	<input type="checkbox"/> Other: _____				
Construction Method:	<input type="checkbox"/> Trench/Open Cut	<input type="checkbox"/> Bore	<input type="checkbox"/> Plow	<input type="checkbox"/> Potholing	<input type="checkbox"/> Other: _____

ALL OTHER INFORMATION

Estimated Start Date: _____ Estimated Completion Date: _____

SIGNATURES

PERMIT VAILD UNTIL END OF CALENDAR YEAR. The applicant has received and agrees that the permitted work shall comply with all permit provisions and conditions of the Utility Accommodation Policy in effect at the time of this application, including assuming responsibility for all claims of damage or injury as provided therein, and with any special provisions listed below or attached hereto, and any all plans, details, or notes attached hereto and made a part thereof.

Signature of Owner: _____	Date: _____
Signature of Contractor: _____	Date: _____
Signature of Municipal Rep: _____	Title: _____ Date: _____

FIVE YEAR WARRANTY AGREEMENT (STARTS UPON ACCEPTANCE OF THE COMPLETION CERTIFICATE)

(for Utility Permits)

RECIPIENT'S INFORMATION

SEND TO:

DE PERE

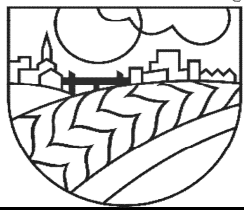

City of De Pere
Attn: Engineer Department
925 S. Sixth Street
De Pere WI 54115
Phone #: 920-339-4061
Fax#: 920-339-4071
Email: dppubwrks@deperewi.gov

OWNER'S INFORMATION

FROM:

Owner Name: _____	Contact Person: _____
Current Address: _____	Emergency Phone: _____
City, State, ZIP : _____	
Phone: _____ Fax: _____	E-mail: _____

CONTRACTOR PERFORMING WORK

Contractor Name: _____	Contact Person: _____
Current Address: _____	Emergency Phone: _____
City, State, ZIP : _____	
Phone: _____ Fax: _____	E-mail: _____

INFORMATION OF WHERE WORK WAS PERFORMED

Street Address/Location Description: _____

Project Description (include depth, width, and length): _____

SIGNATURES

As the authorized representative of the above-listed company, I hereby agree to accept the financial responsibility for the maintenance of the designated utility work associated with the project (utility work, roadway, sidewalk, curb) on or along the above-mentioned Municipal road, for the period of five (5) years, from the restoration/final acceptance date of the project completion certificate. Lawn restoration and landscaping shall be a one (1) year warranty. The warranty begins on the date of acceptance by the Municipality. In an emergency situation, or if the Municipality notifies you of a maintenance problem, and it is not resolved in a timely manner, the Municipality will perform the maintenance on the project and all costs would then be billed to the responsible party(ies).

Signature of Authorized Representative: _____

Date: _____

Printed Name: _____

Title: _____

FOR OFFICE USE ONLY

NOTIFICATION OF RECEIPT

Signature of Municipal Representative: _____

Date Accepted: _____

Printed Name: _____

Title: _____

COMPLETION CERTIFICATE

(for Utility Permits)

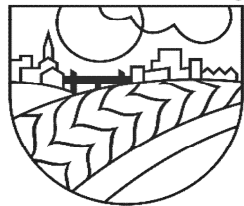
RECIPIENT'S INFORMATION**SEND TO:****DE PERE**[®]

City of De Pere
 Attn: Engineer Department
 925 S. Sixth Street
 De Pere WI 54115
 Phone #: 920-339-4061
 Fax#: 920-339-4071
 Email: dppubwrks@deperewi.gov

OWNER'S INFORMATION**FROM:**

Owner Name: _____
 Current Address: _____
 City, State, ZIP : _____
 Phone: _____

Contact Person: _____
 Emergency Phone: _____
 Fax: _____
 E-mail: _____

INFORMATION OF WHERE WORK WAS PERFORMED

Street Address/Location Description: _____

Project Description (include depth, width, and length): _____

SIGNATURES

The work requested under the above-mentioned utility permit has been completed. The Municipality can now review to insure proper restoration to the affected Municipal right-of-way has been made.

Signature of Authorized Representative: _____

Date: _____

Printed Name: _____

Title: _____

FOR OFFICE USE ONLY

UTILITY PROJECT FIELD INSPECTED BY

Signature of Municipal Representative: _____

Date Accepted: _____

Printed Name: _____

Title: _____

UTILITY PROJECT PERMIT PROVISIONS AND CONDITIONS OF APPROVAL
FOR RIGHT-OF-WAY EXCAVATION AND OCCUPANCY

Pursuant the following requirements shall apply to the permit to construct communication, fiber optic, cable/video, utility service, and excavation in the street right-of-way for all work for which the City of De Pere has permitting authority. The following provisions and any attached special provisions shall govern.

PERMIT APPLICATION

A Utility Project Permit or minor permit is required for all utility projects in the City of De Pere street right-of-way, City of De Pere public property, and platted public utility easements and shall be obtained by application to the Dept of Public Works on the forms provided by the City of De Pere

Project permit forms include the Project Permit Application, Warranty, and Project Completion forms.

1. A utility project permit application shall include a properly signed Utility Project Permit Application form and Construction Warranty form and shall be provided to the permitting authority along with engineering plans and required fee. The Completion Certificate shall be provide upon completion of the project.
2. A Minor Project Permit Application is required for maintenance work on an existing utility system or for single or two family utility services.

DEFINITIONS

1. Utility Project: Communication, fiber optic, video cable, natural gas, electric, or other underground utility service or similar non-municipal utility service that includes project installation work including equipment, above or below grade structures, multiple overhead poles; and extends one or more city blocks, or more than 1000 feet on a rural roadway.
2. Utility Project Permit: The permit required for a Utility Project.
3. Maintenance: Repairs, replacement of cable, minor modifications which do not include additions of structures, or other work which does not modify the existing function or capacity of the existing utility system are considered routine maintenance work.
4. Minor Permit: A Minor Permit is required for maintenance work, or for utility service located in the right-of-way or under a roadway to service a single or two family residence.

STANDARD PROVISIONS

1. The applicant shall comply with the City of De Pere Municipal Code of Ordinances pertaining to street obstruction and shall obtain necessary permit(s) prior to starting any work with the exception of an emergency in which case the applicant shall have until the next business day to apply. Applicant shall assume all responsibility for any claim of damage or injury made against the City of De Pere caused by such street obstruction. Further, the applicant shall sign and barricade the work zone in accordance with applicable manual of Uniform Traffic Control Devices. Warning signs and barricades shall be in place prior to start of permitted work and shall stay in place until all permit associated work is completed.
2. The applicant shall comply with Section 22-11, City of De Pere, Municipal Code of Ordinances, pertaining to street excavation and shall assume all responsibility for any claim of damage or injury made against the City of De Pere allegedly caused by such excavation. The applicant shall assume all responsibility for any claim of damage or injury made against the City allegedly caused by the work undertaken pursuant to the utility permit.
3. The applicant shall assure that proper erosion control measures are implemented prior to and at all times during work operations according to the Technical Reference Guide contained in the Municipal Code of Ordinances. The applicant shall be responsible for providing and maintaining erosion control measures to

protect all restored areas upon completion of the permitted work until the replacement vegetation achieves a minimum 70% cover. Where applicable, applicant shall obtain a Construction Site Erosion Control Permit pursuant to Ordinance No. 42-04, City of De Pere Municipal Code of Ordinances. Applicant shall assume all responsibility for any claim of damage or injury made against the City allegedly caused by its erosion control measures or failure thereof.

4. A copy of the Utility Project Permit and Construction Site Erosion Control Permit, along with plans and specifications, shall be kept at the work site and shall be made available for examination by the City of De Pere representative at all times.
5. Permitted utilities shall be installed a minimum horizontal clearance of eight (8) feet and minimum vertical clearance of two (2) feet from existing sanitary sewer, storm sewer, and water mains; unless otherwise approved by the Director of Public Works.
6. All costs for removing, altering, replacing, constructing, and maintaining the utilities installed under this permit shall be the sole responsibility of the applicant, its successors or assigns. The permitted facilities shall, if necessary, be altered at the expense of the applicant to facilitate alteration, improvement, or maintenance of City of De Pere facilities, as may be ordered by the Director of Public Works.
7. Permitted facilities shall be located as defined within this permit and constructed as shown on the engineering plans provided with the utility permit application. Any part of a facility found to be otherwise located shall be subject to correction to such extent as the Director of Public Works may specify and at the sole cost of the applicant.
8. It shall be responsibility of the applicant to determine the location of, and protect or cause to be protected from any damage, all sewer and water utilities already in place in the area of the permitted work. Any damage caused to existing sewer and water utilities by the applicant due to the permitted work shall be repaired immediately and all costs associated with the repair shall be the sole cost of the applicant. The Director of Public Works may require televising the existing sewer utilities, at the sole cost of the applicant, to confirm existing utilities were not damaged during the work.
9. All notification of adjacent property owners is the responsibility of the applicant. At least seventy-two (72) hours before starting the work the applicant shall provide a notice to all affected property owners including the person with phone number to contact with any questions or concerns during construction. Emergency work notifications shall be made as soon as practical.
10. This permit does not transfer any land; nor give, grant or convey any land right, right in land, nor easement.
11. The permitted work shall be coordinated, and in no case interfere with any public improvements being undertaken at the same time. It shall be the responsibility of the applicant to obtain the information from the City of De Pere regarding upcoming sewer and water projects in the proposed work area and incorporate this information into the design and construction plans for the work to minimize interferences, improve safety and optimize the location of the utilities.
12. Construction work and site restoration shall be in accordance with the applicable sections of the City of De Pere Standard Specifications and Construction Standards for Public Works Construction, current edition.
13. Pavement excavations shall be permitted only in locations authorized by the Director of Public Works. Unless otherwise authorized, any utility pipes or cables installed across and beneath pavement shall be installed by jacking and/or dry augering, with no open cut excavation permitted between points no less than five (5) feet outside the back of curbs or outer shoulders.

14. Any turf area disturbed by the permitted work shall be restored in accordance with the City of De Pere terrace restoration policy. Turf restoration shall be completed within fourteen (14) days of completion of the utility work.
15. Any non-metallic underground pipe or cable shall include a metallic tracer wire or a metallic tracer tape at the same alignment and depth as the carrier, cable or conductor. Such installation shall be as specified by the City of De Pere.
16. Installation of above ground permanent markers within the public right-of-way is prohibited, unless otherwise approved by the Director of Public Works.
17. Manhole covers, water shut-off and regulator valves, and like facilities shall be adjusted to the level of the immediately adjacent grades.
18. Sewer lateral locations are not provided by location services. Approximate locations of laterals are available by request through Public Works-Engineering.

ENGINEERING REQUIREMENTS

1. Provide two (2) sets of engineering plans with the Utility Permit Application. The plans shall include the following:
 - a. Approximate location and depth of all proposed cable, fiber optic, structures, cabinets and access boxes. Approximate dimension of proposed utilities and structures to the street right-of-way.
 - b. Show all planned excavations and bore pits for the project. Any excavations added after issuance of the permit must be approved by the City of De Pere.
 - c. Show all municipal sewer and water, manholes, laterals, and storm inlets.
 - d. Site restoration including topsoil, seeding, and mulch must be specified to match preconstruction conditions.
 - e. Utility cabinets, structures and other above grade facilities are to be located on private property easements or on public utility easements outside the right-of-way unless otherwise approved by director of public works.
 - f. Landscaping of all above grade structures must be provided and approved by the City of De Pere. All cabinets must be shielded from view by landscaping within Right of Way (ROW).
2. Applicable requirements of the City of De Pere Construction Site Erosion Control Ordinance shall be shown on the plans.
3. Incorporated by reference is the Brown County Accommodation Policy Nos. 96.01 thru 96.64, pages 1-56, dated January 2010. Please refer to these requirements.
4. Record drawings of the construction work shall be provided to the City of De Pere.

STREET AND ROADWAY EXCAVATION

1. Excavations occurring within an existing asphalt or concrete surface shall be saw cut full depth prior to removal. Excavations occurring within the limits of existing or proposed pavements, driveways, parking areas, and sidewalks shall be backfilled in 12-inch layers with WDOT highway design manual approved and mechanically compacted to obtain 95% standard proctor density or compacted to original conditions, whichever is greater. All surplus excavation material shall be disposed of by the applicant. Excavations shall be closed by the end of the workday. Excavations within an existing asphalt or concrete street surface shall be restored as follows:
 - a. Asphalt streets – Replace to original depth with bituminous concrete binder and surface material (see standard details).

- b. Concrete streets –Replace to original depth with concrete pavement installed by a City of De Pere pre-qualified contractor.
 - c. Curb & Gutter –Work to be performed by a City of De Pere pre-qualified contractor, per standard specification.
 - d. Driveways & Sidewalks –Work to be performed by a City of De Pere pre-qualified contractor, per standard specification.
 - e. Cored Potholes – Repair using infrared patching on asphalt streets, and filling with concrete on concrete streets. Potholes must not exceed 10” diameter.
 - f. Patching - During periods when bituminous concrete material is not available the applicant may request permission to utilize cold mix asphalt material. When requested and approved by the City of De Pere the applicant may use cold mix as a temporary patch until final repairs are made. Consideration in granting this approval include the availability of hot mix asphalt and the number of repairs to be made. The applicant shall be responsible for maintaining the cold mix until the final repair is completed.
2. Surface tolerances for street repairs shall meet the standard for new construction. The finished surface of the street repair, when tested with a ten (10) foot straightedge parallel to the centerline or perpendicular across joints, will show variations measured from the testing face of the straightedge to the surface fo the street repair shall not exceed one-quarter (1/4) inch. In the event pavement variances exceed the 1/4 – inch requirement or other quality factors during the five-year warranty period, reasonable consideration of the condition of the surrounding street will be made in determining compliance with the Five-Year Warranty Agreement.

WARRANTY REQUIREMENTS

1. A Five Year Warranty Agreement is required stating that the applicant shall be responsible for maintenance and repair costs of any open-cut trench, pavement failure, sidewalk and curb construction for a 5-year period after submission of the signed project Completion Certificate.
2. The City of De Pere may require the applicant at its sole cost video televise any existing underground municipal utilities adjacent to the applicant’s work to confirm that no damage was incurred to the municipal utilities.

Date: July 22, 2016

City of De Pere

Pavement Repair – Utility Excavation

EXCAVATION

Asphaltic Concrete Pavement

Depth of Excavation

Type 1 Excavation – Work occurs within the street in the asphaltic concrete pavement or crushed aggregate base course, or a maximum depth of 24 inches.

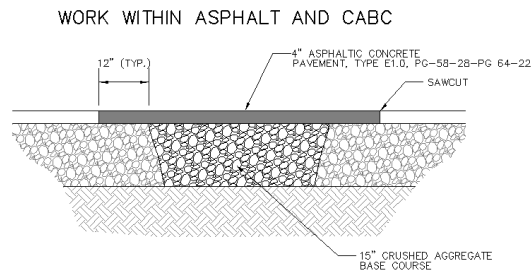

- (1) Pavement replacement is to extend 12 inches beyond the excavation limits.
- (2) Pavement replacement may be extended to an existing joint line or crack depending on the location of the excavation.

Type 2 Excavation – Excavation is to a depth greater than 24 inches

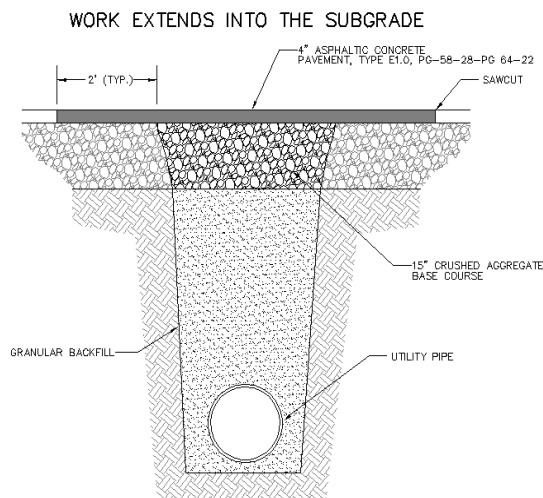

- (1) Pavement replacement is to extend 24 inches beyond the excavation limits.
- (2) If excavation occurs outside of the travel lane, repair to the edge of the travel lane (see detail).
- (3) If excavation occurs in a travel lane, repair the travel lane (see detail).

The travel lane is generally between 10 and 12 feet wide. The width may vary dependent on street width and parking restrictions on a street. The location of the travel lane will be determined by the engineer.

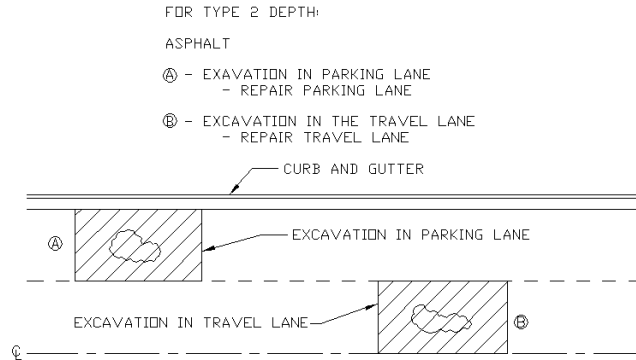

Other Notes –

- (1) If excavation occurs behind the curb and involves curb and gutter removal, a two foot wide strip of asphaltic concrete pavement shall be removed and replaced in front of the curb and gutter.

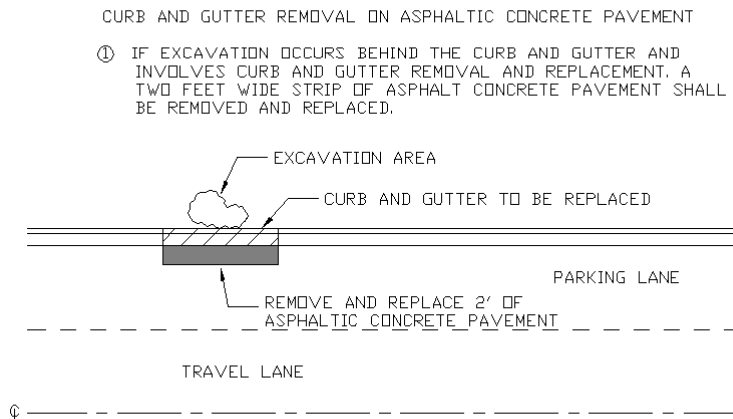

City of De Pere

Pavement Repair – Utility Excavation

CONCRETE PAVEMENT

Depth of Excavation

Type 1 Excavation – Work occurs within the street in the concrete pavement or crushed aggregate base course, or a maximum depth of 24 inches.

WORK WITHIN CONCRETE AND AGGREGATE

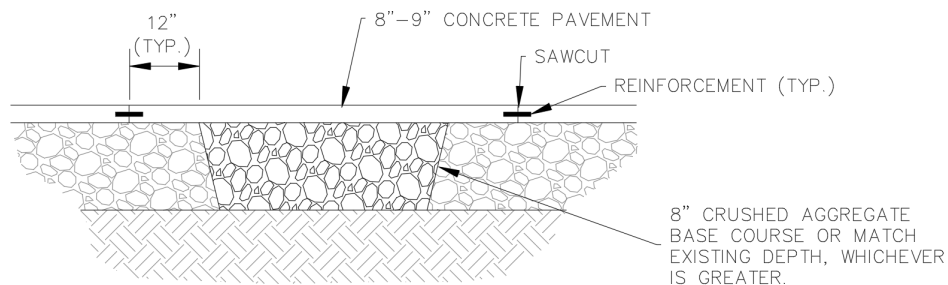

- (1) Pavement replacement is to extend 6 inches to 12 inches beyond the excavation limits. Utilize pavement ties and dowels into adjacent pavement for concrete depth greater than 7 inches.
- (2) Pavement replacement shall be extended to an existing joint line or crack depending on the location of the excavation.
- (3) For manhole structure cover repair or adjustment, box outs may be acceptable if approved by the engineer.

Type 2 Excavation – Excavation is to a depth greater than 24 inches

WORK EXTENDS INTO THE SUBGRADE

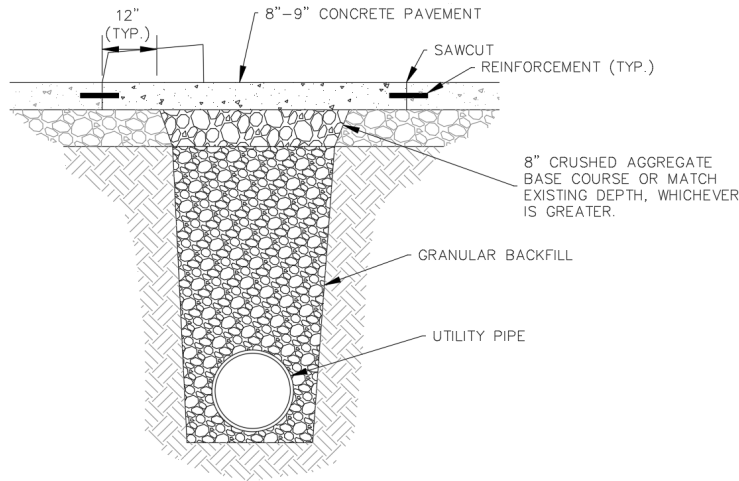

- (1) Pavement replacement is to extend 12 inches beyond the excavation limits. Utilize pavement ties and dowels into adjacent pavement for concrete depth greater than 7 inches.
- (2) Replace pavement to a joint line (see detail) for pavement less than 15 years old.
- (3) Replace at least 1/2 of panel per the detail below for pavement greater than 15 years old.

FOR TYPE 2 DEPTH:
 CONCRETE STREET LESS THEN 15 YEARS OLD
 ① - REPAIR TO A JOINT LINE, INSTALL DOWELS FOR 8" CONCRETE.

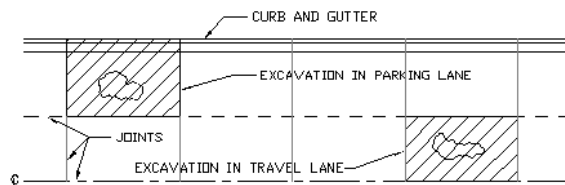

FOR TYPE 2 DEPTH:
 CONCRETE STREET GREATER THEN 15 YEARS OLD
 1. CONTRACTOR TO REMOVE TO THE JOINT IF REMAINDER OF PANEL IS CRACKED.
 2. CONTRACTOR TO SAW CUT 12 INCHES BEYOND TRENCH WALL OR DAMAGED CONCRETE. MINIMUM PATCH WIDTH MUST BE 7 FEET.
 3. INSTALL DOWEL BARS FOR 8" CONCRETE.

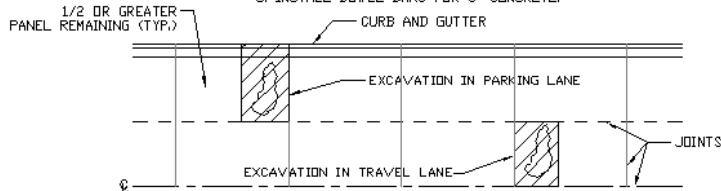

Other Notes – If excavation occurs behind the curb and involves curb removal on integral pavement, a two foot wide strip of concrete pavement shall be removed and replaced from the face of the curb

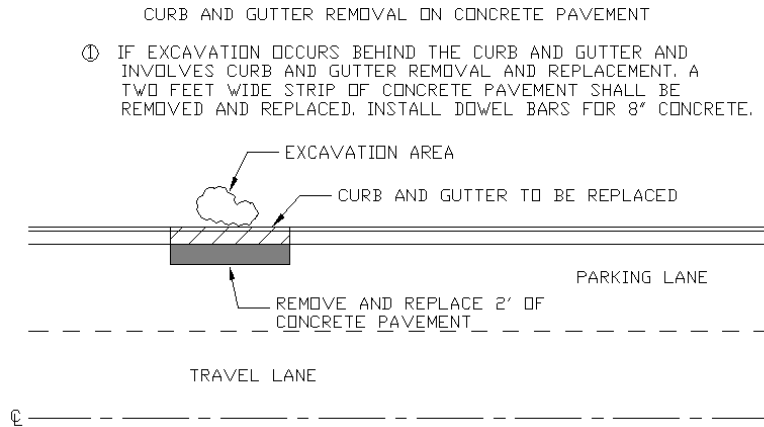

PAVEMENT CORES OR SOIL BORING RESTORATION

- A. PAVEMENT CORES OR SOIL BORINGS SHALL BE RESTORED PER THE DETAIL AND SPECIFICATIONS BELOW

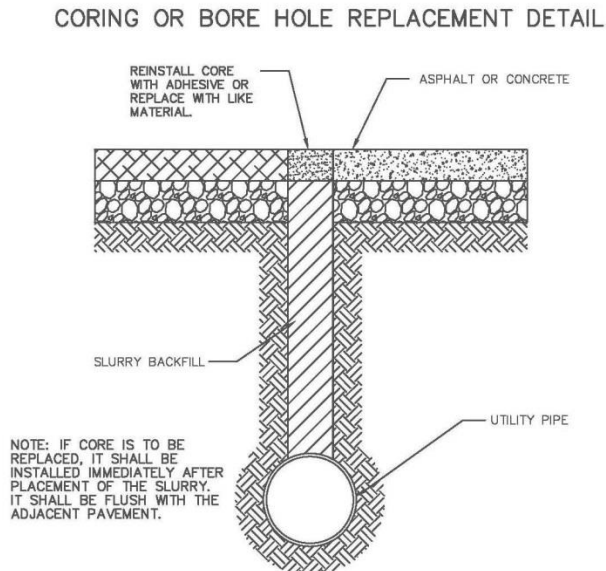

B. ENGINEERED SOILS AND AGGREGATES (SLURRY BACKFILL) SPECIFICATIONS:

1. General Requirements

- a. Material shall be placed in a clean concrete mixer truck and thoroughly mixed.
- b. No additional water will be allowed. The weights are damp weights.
- c. Just prior to placing the slurry backfill, the mixer shall be run at mixing speed for one full minute to assure an even mixture.

2. Gradation/Mix Ratio

- a. Slurry backfill ratio per cubic yard for backfilling shall conform to the following table:

Per Cubic Yard	
Material	Weight/Amounts
Sand	1,350 lbs
A-7	750 lbs
A-6	1,150 lbs
Water	25 Gallons

- b. Sand for slurry backfill shall be a granular material having at least 90% passing the No. 4 Sieve and predominantly retained on the No. 200 Sieve.